

PROPOSED HOUSE IN S.NO. 97/3B1, PUTHAGARAM VILLAGE,
SAIDAPET TALUK, CHENGLEPET M.G.R DISTRICT.

OWNER : THIRU. R. GOKULAKRISHNAN

APPROVAL AUTHORITY

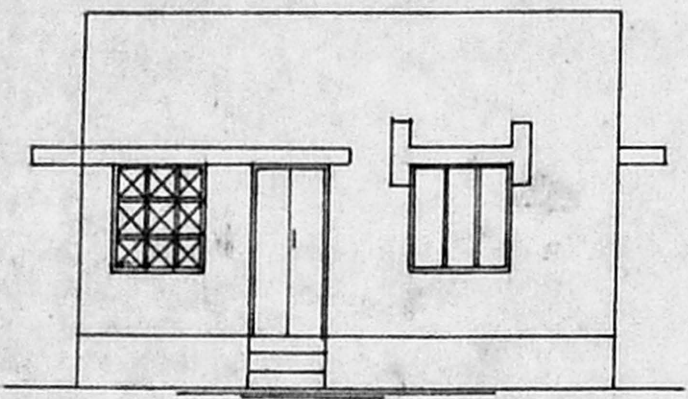

FRONT ELEVATION

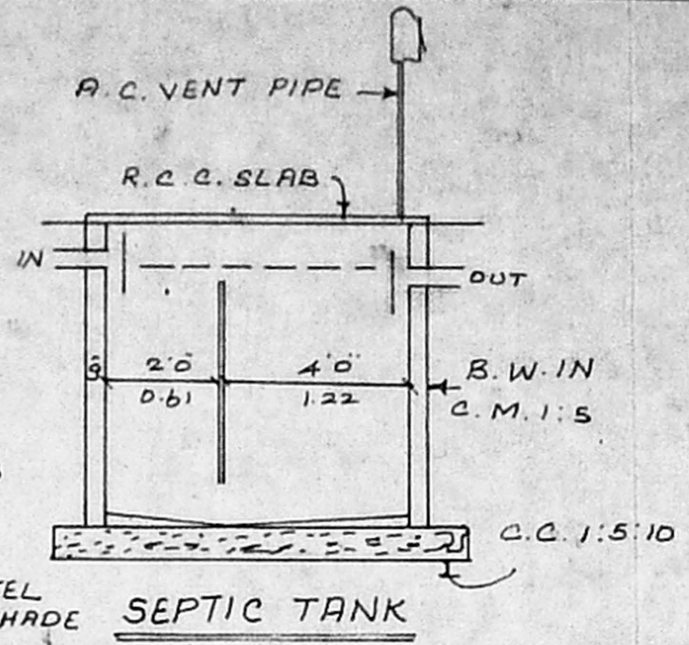
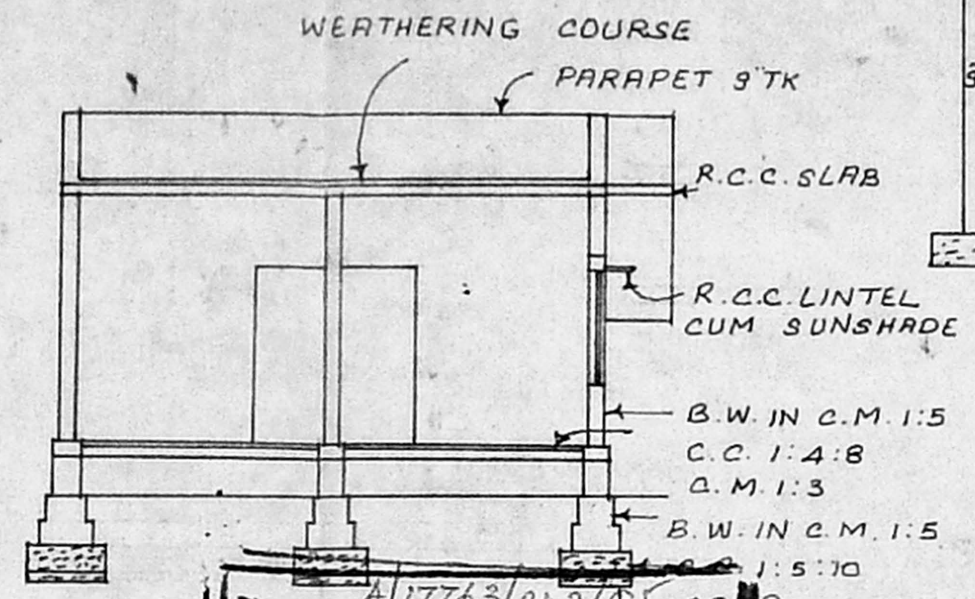
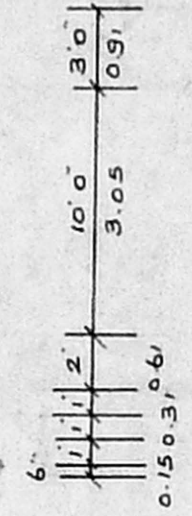

SEPTIC TANK

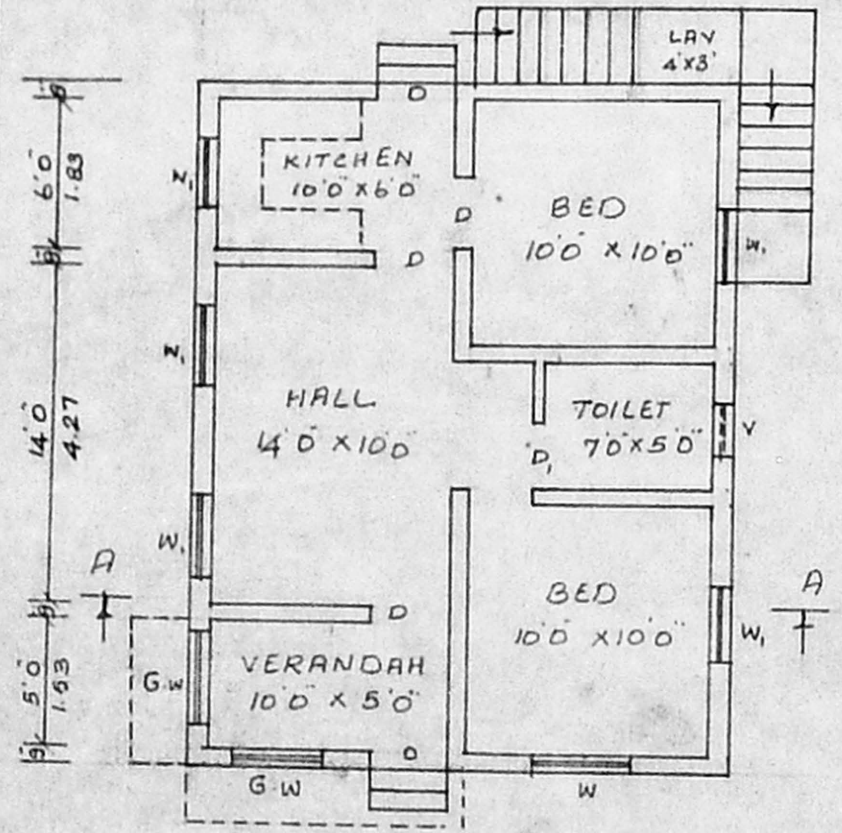
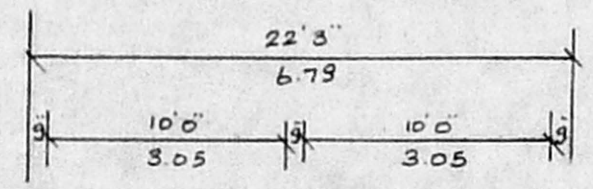

PLAN

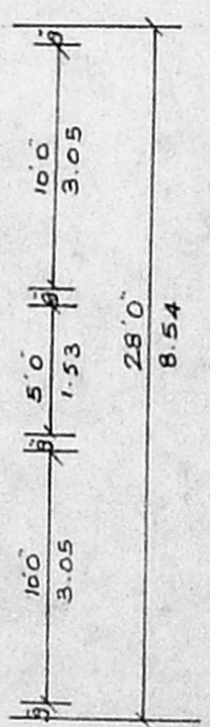

H. SUGUNA PLOT

APPROVED
 SUBJECT TO THE CONDITIONS IN
 THIS OFFICE LETTER
 FOR MEMBER SECRETARY
 MADRAS METROPOLITAN
 DEVELOPMENT AUTHORITY
 MADRAS - 600 008

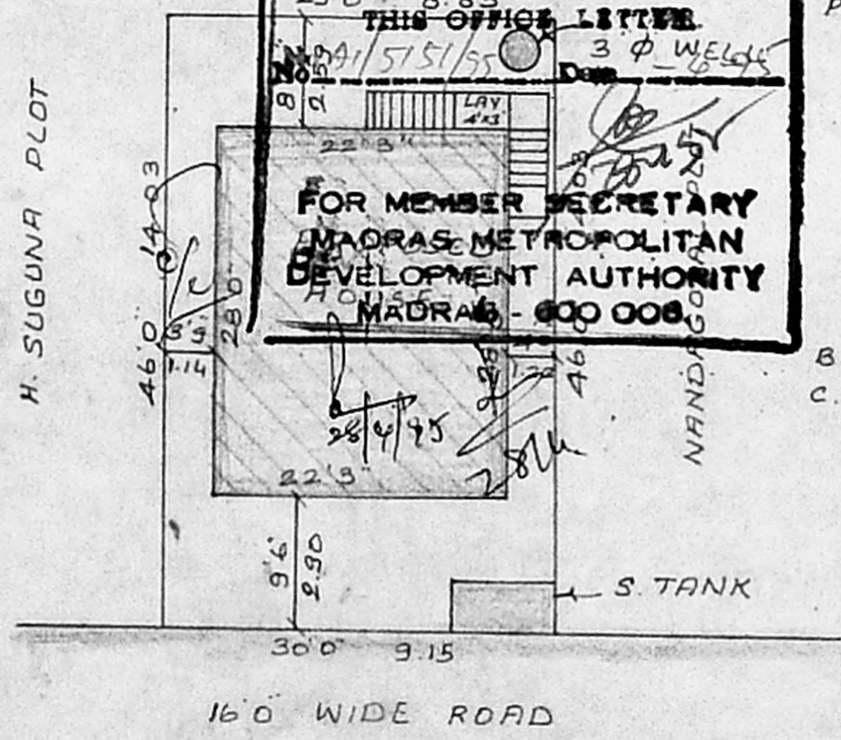

SITE PLAN

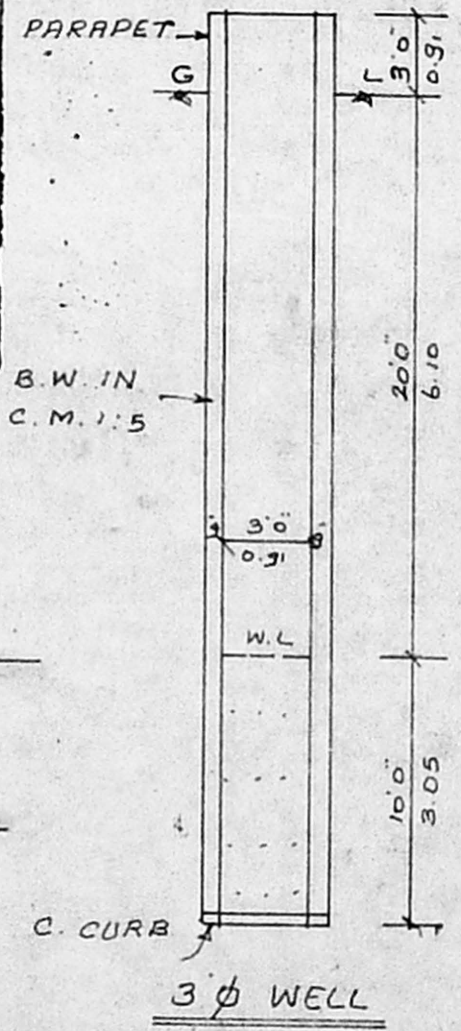

3 phi WELL

SPECIFICATION AS IN SECTION

REFERENCE

D : DOOR : 3'0" x 7'0" W : WINDOW : 4'0" x 4'6"

D₁ : " : 2'6" x 6'6" W : " : 3'0" x 4'6"

V : VENTILATOR : 2'x1'6" G.W. : 4'0" x 4'6"

AREA DETAILS :

PLOT AREA : 1357 SQ.FT 126.07 M²

PLINTH AREA : 623 SQ.FT 57.88 M²

PLOT COVERAGE : 46% F.S.I. : 0.46

COLOUR INDEX :

PROPOSAL : RED ROAD : GREEN

SCALES : BUILDING PLAN : 1:100

SITE PLAN : 1:200

SCHEMATIC PLAN
 A1/5151/95
 24/3/95

MANIVANNAN, B.Sc., D.C.E.
 CONSULTING CIVIL ENGINEER,
 LICENSED SURVEYOR,
 No 222
 POZHAI TOWN PANCHAYAT,
 Off: 89, GANDHI STREET,
 POZHAI, MADRAS-66,
 SEMBULIVARAM, MADRAS-67.

ENGINEER

R. Gokul
 OWNER